NILSSON **MODEL 715**

SOLID STATE

PIPE & CABLE LOCATOR

INSTRUCTION MANUAL

NILSSON ELECTRICAL LABORATORY, **INC.**
SPECIALISTS IN ELECTRONIC AND ELECTRICAL MEASUREMENTS

NILSSON ELECTRICAL LABORATORY, INC. PIPE & CABLE LOCATOR MODEL 715

CONTENTS

		Page		
Section 1	PHYSICAL CONSTRUCTION		Section 6	OPERATING NOTES
1.1	Transmitter	2-3	6.1	Distance and depth
1.2	Receiver		6.2	Cable opens and grounds
1.3	Optional equipment		6.3	River crossings
Section 2	THEORY OF OPERATION	4	6.4	Bends and stub ends
Section 3	OPERATING INSTRUCTIONS	4-5	6.5	Branch taps and foreign contacts
Section 4	ANTENNA POSITIONS	5-6	6.6	Building electric circuits and piping
4.1	Maximum signal		Section 7	BATTERIES AND REPLACEMENT
4.2	Minimum or null position			10
4.3	Depth determination		Section 8	REPLACEABLE PARTS AND REPAIRS
Section 5	ESTABLISHING SIGNAL CURRENT CIRCUIT	6-7		10

☆☆☆

MODEL 715



The Model 715 contains no moving parts, such as vibrator contacts or relays, to wear out and require adjustment. Full advantage is taken of modern solid state technology to provide efficient transfer of a signal current into a ground circuit and accurate tracing of the signal in the substructure being investigated.

ASK US FOR TECHNICAL INFORMATION ABOUT YOUR PARTICULAR INSTRUMENT REQUIREMENTS Page 1

Section 1

PHYSICAL CONSTRUCTION

The physical design emphasizes versatility in the use of accessories to best suit the needs of the problem at hand. The locator is light weight, rugged and compact, intended for industrial use under adverse field conditions. The entire unit is housed in a deep drawn vinyl clad aluminum case, with storage space for accessories. The transmitter is mounted in the case with a panel containing all controls. The receiver, removed from its storage in the case, is designed as a basic "handle" into which antenna and output accessories are plugged.

1.1 TRANSMITTER

The transmitter is designed to operate from a 12 volt D.C. power source. It contains a circuit that generates a distinctive A.C. signal. The pitch of the signal is variable by means of the "FREQUENCY" control. The signal is also periodically interrupted to make the tone more distinctive. The rate of interruption is adjustable with the "RATE" control.

With the use of these two controls, the signal may be adjusted to be readily distinguished from any background noise such as power line hum, traffic noise, etc.

Three output impedance ranges are provided, selected by the "IMPEDANCE" switch. This allows the operator to select the best match of transmitter output circuit to the existing conditions.

A low battery warning lamp is provided. This is NOT a pilot light. It will ONLY light when the battery voltage is down to 9-10 volts, indicating the need to replace or recharge the battery.

1.2 RECEIVER

The receiver, stored behind a clamp under the transmitter, is housed in a square phenolic tube. It contains input circuitry, on-off volume control, amplifier, batteries and an output jack. It forms the handle for the flat coil antenna.

In operation the antenna is inserted into a jack at the volume control end—and headphones or an output accessory is plugged into the jack at the opposite end. The unit is now ready for use. Whenever the headphones or other output device is unplugged, the batteries are automatically disconnected, preventing accidental battery drain.

The antenna coil is moulded in an epoxy compound and mounted on a hinge joint rod. A bubble level is moulded in which indicates both horizontal and 45 degree inclination.

The proper output *impedance* match is 600 ohms. The headphones supplied are of 600 ohm impedance. (Do not confuse impedance with the resistance of the phones.)

The aluminum plate under the volume control as well as the receiver name plate strip are connected to the receiver ground. When holding the receiver in a normal manner it assures body contact to receiver ground and prevents feedback howl when headphones are used. When working with gloves on and using headphones, it is recommended that some simple way, such as a bare wire through a finger of the glove, be used to establish finger contact with receiver ground.

1.3 OPTIONAL EQUIPMENT

The Model 715 locator consists of case, mounted transmitter, antenna, receiver, one extension rod and 600 ohm headphone. The additional options listed below are available.

LOUD SPEAKER

The loud speaker is housed in a small metal case containing a transformer and 2¼ inch speaker, arranged to plug into the output jack in place of the headphones. The receiver amplifier has ample drive for this and a loud clear signal is heard. A clip is provided in the case cover for storage.

OUTPUT METER

The output meter is housed in a small metal case. It is a ruggedized sealed meter, properly damped to visually display and follow the received signal. A jack in the case permits using the headphones at the same time, providing an audio-visual display for exacting work.

ANTENNA EXTENSION ROD

The antenna and receiver combination provides a "wand" 17 inches long. One extension rod (supplied) extends this to 28 inches. Additional 11 inch extension rods may be purchased.

ANTENNA CABLE

The antenna may also be coupled to the receiver by a cable. Thus an extra antenna may be mounted on a truck and wired into the receiver in the cab for riding surveys. When an area for close investigation is found, the receiver is disconnected and another antenna added in the usual manner. Cables are supplied to order at length specified.

MODEL 110 RECHARGEABLE 12 VOLT BATTERY PACK

Will outlast hundreds of 12 volt lantern batteries. Full description on page 10.

Section 2 THEORY OF OPERATION

The Model 715 operates on what is known as the "conductive" principle.

The transmitter generates a distinctive electrical signal current. By proper application, *the* current is caused to flow in a loop circuit part of which is the pipe or cable (hereafter called the conductor) being investigated.

An electric current flowing in a conductor generates a magnetic field around that conductor in a circular pattern. If an antenna coil is placed within that field, an electric current is induced in the antenna. This current can be amplified and heard in headphones or loud speaker.

The relative loudness of the signal, together with the position of the antenna coil, enables the operator to determine with precision the course of the conductor and its depth below ground surface.

An understanding of these principles, and experience in the use of this equipment, enables the operator to deduce many other factors, such as location of branches, contacts with other metallic structures, condition of insulating joints, location of opens and grounds, etc.

Section 3 OPERATING INSTRUCTIONS

The "OUTPUT" binding posts of the transmitter should be connected to the conductor in one of the several ways described in Section 5.

Remove the receiver from the case and assemble with the antenna and headphones or other output accessory. Turn on both units.

NOTE

After the transmitter has been turned on, the operator should not contact the output binding posts or wiring. A shock may be received which is not dangerous but may be annoying, especially in the "H I" position of the impedance switch.

Listen to the signal and adjust the "FREQUENCY" and "RATE" controls for the most distinctive tone for the conditions.

Listen to the received signal some twenty feet away AT A LOW VOLUME SETTING. Try the three positions of the "IMPEDANCE" switch and select the one which gives the best signal.

You are now ready to trace the path of the conductor. Best receiver operation will occur with the volume set to the lowest level at which it can be heard comfortably. This will reduce the effect of background noise and make small changes in signal strength more easily detected.

Section 4
ANTENNA POSITIONS

It is important that the operator gain a thorough understanding of the relationship between the position of the antenna, the strength of the signal received, and the position of the conductor.

4.1 The *loudest* (MAXIMUM POSITION) signal is heard when the edge of the antenna disc points directly at the conductor and the disc is *parallel* with the conductor. (Figure 1A) The signal fades as the disc moves away from this position. If the disc is exactly at *right angles* to the conductor, no signal will be heard.. (Figure 1 B)

4.2 *Minimum signal will be heard* (NULL POSITION) when the flat side of the disc faces the conductor and is parallel with it. (Figure 2)

A very critical position can be found where the signal is inaudible. This position is very sharp, often only a fraction of an inch wide, depending on diameter of conductor, and depth.

With the disc held flat, close to the ground, with the bubble centered, the conductor lies directly below the center of the disc. This null is very accurate. However another metallic structure close by may disturb it to some extent.

Usual practice is to use the maximum position

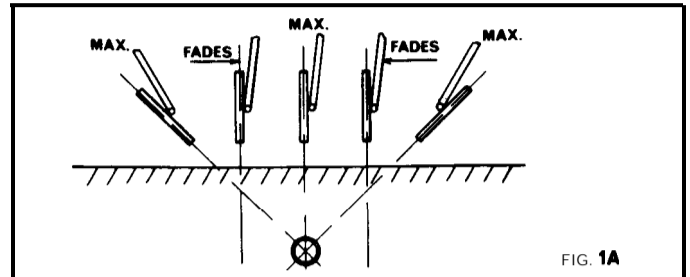

FIG. 1A

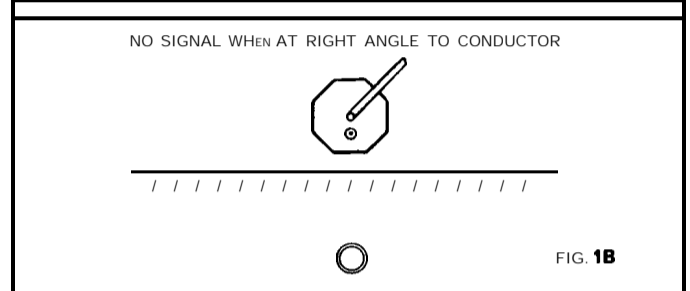

FIG. 1B

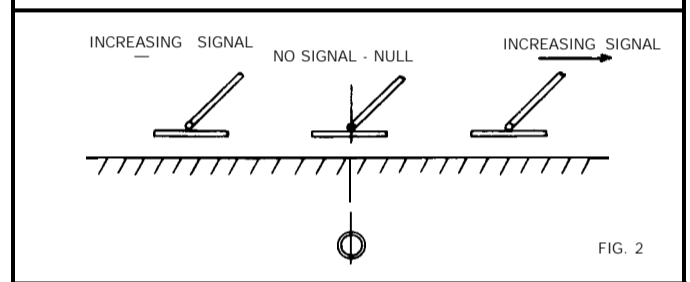
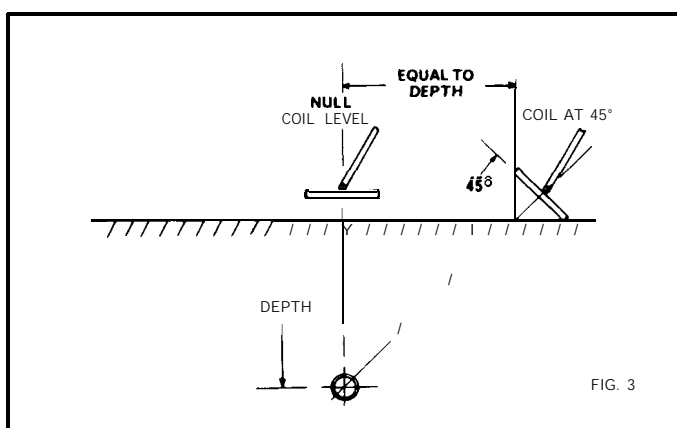

FIG. 2

for general quick tracing and the NULL position for pin pointing the location.

4.3 DEPTH DETERMINATION

When an exact null (4.2) is obtained, the position of the center of the disc is marked on the ground surface. The disc is then tipped to 45 degrees (bubble touching the outer edge of the ring on the level). The disc is then moved horizontally sideways from the mark until another NULL is obtained. The distance moved is equal to the depth of the conductor below the first NULL. (Figure 3)



Page 6

Section 5

ESTABLISHING THE SIGNAL CURRENT CIRCUIT

The signal current is established by a number of methods, depending upon the circumstance. The objective is to establish a series loop circuit between the output binding posts which will include the conductor as a part. The signal current travels through metallic conductors just as any other current would. Its nature is such that it will pass through the soil surrounding the conductor. It will also pass through the electrical capacitance between the conductor and its surroundings. All these paths are taken advantage of in setting up the circuit.

a. When two points on the conductor are available some distance apart and the path between them is to be traced, one output binding post is connected to one point on the conductor. An insulated wire is run from the other binding post to the second point on the conductor. The wire should be kept about 50 feet away from the probable path of the conductor to minimize the signal from the wire. The low impedance switch position will probably be best in this situation. Be sure that all connections are tight. (Figure 4)

b. When one point on a conductor is available and there is within reaching distance a metallic structure which may be used as a ground connection, connect the point on the conductor to one output binding post, and the other to the grounding structure. The loop circuit is then closed between them by soil conductance and capacitance. The signal will be heard in both the conductor and the grounding structure. The best impedance will be found by trial. (Figure 5)

Examples of grounding structures are:

- Water systems
- Gas systems
- Steel building frames
- Power circuit ground wires or conduits
- Manhole and drain covers
- Valve boxes
- Chain fencing and metal fence posts
- Metal traffic signs
- Metal road guard rails

c. When one point of the conductor is available and no convenient ground is nearby, a metal rod may be driven for a ground approximately 50 feet or so away from the probable path of the conductor and the connection completed as in b. In many cases a good signal is obtained with a rod about 18 inches long pushed by hand into a moist soil. If a high resistance soil condition is found, a longer rod should be driven several feet into the ground. Water poured around the rod will also help. (Figure 6)

On a pipe protected with buried anodes, the connection to the anode may be opened and the anode used as a ground.

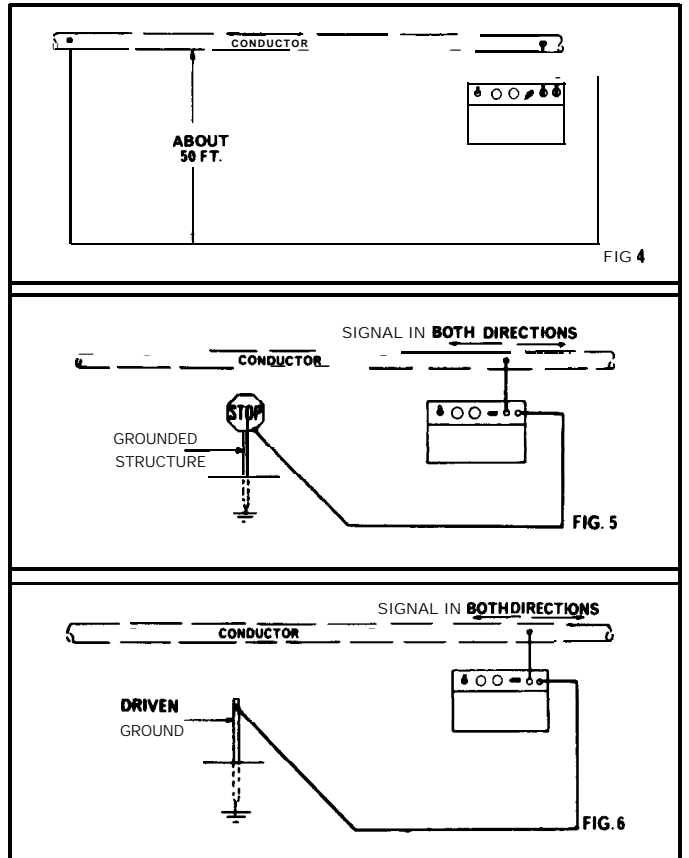

Section 6
OPERATING NOTES

6.1 The distance a signal will carry depends upon a number of conditions. If the conductor is a well coated pipe, it is not uncommon to follow the signal for several miles in each direction from the point of connection. If this point is made near one terminus of the line, all the signal goes in one direction, and a greater distance is achieved.

On a bare line the signal can be expected to carry several hundred feet. On pipe networks the distance will also depend on the number of branches which absorb signal.

Insulated joints cause a sharp drop in signal as they are passed. This is used as an indication of insulator condition. If the insulators can be shorted out as they are reached in succession, the line can be surveyed without moving the transmitter, and the shorts removed on retrace.

The depth at which a conductor can be effectively located depends largely on the strength of the signal current. Particular attention should be given to transmitter connections. Depths of 20 to 30 feet are possible.

6.2 When tracing a buried cable, a sudden loss of signal along the path means either an open or ground.

If open, a traverse around the point of loss will not reveal any signal in another direction. However another strong signal in another direction indicates a bend. If the second signal widens out and becomes "mushy", the probability is that a ground exists at that point due to signal current leaving the cable and spreading out in the soil. (Figure 7)

6.3 A pipe or cable may be traced at a river crossing by connecting the transmitter near the bank and following the signal out into the river in a boat. Two stations on shore, equipped to take bearings on the boat on signal, will enable the course of the conductor to be plotted.

6.4 BENDS AND STUB ENDS: When the signal fades out on a pipe run, it may mean a stub end or change in direction. Sweeping a traverse around the point of signal loss may reveal one or two signal paths in another direction, indicating an elbow or T connection. (Figure 8)

6.5 BRANCH TAPS AND FOREIGN CONTACTS: Branch taps such as water or gas services off a main can be found by walking to one side of the main, holding the antenna as in Figure 1 B. Very little signal will be heard from the main, but each tap will produce a signal as it is reached. (Figure 9)

In the same manner, a strange signal where none should exist would indicate a contact with a foreign

conductor which is taking off signal current.
6.6 BUILDING ELECTRIC CIRCUITS AND PIPING: Active power cables may be traced with the receiver only. The power hum and appliance noise acts just the same as signal current.

Wiring conduits may be traced by setting up a loop circuit such as in Figure 4, connecting the far end of the conduit to a water or gas line to complete the loop back to the transmitter.

Conductors buried in concrete floor slabs will usually respond to the ground return circuit of Figure 5, using a ground connection to the building frame.

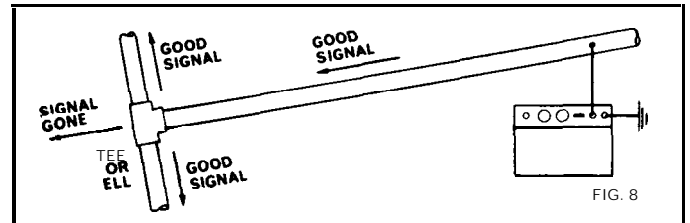

FIG. 8

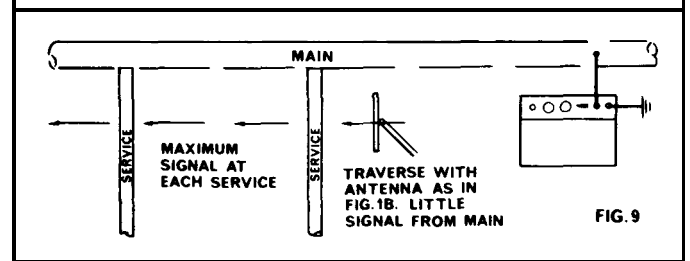

FIG. 9

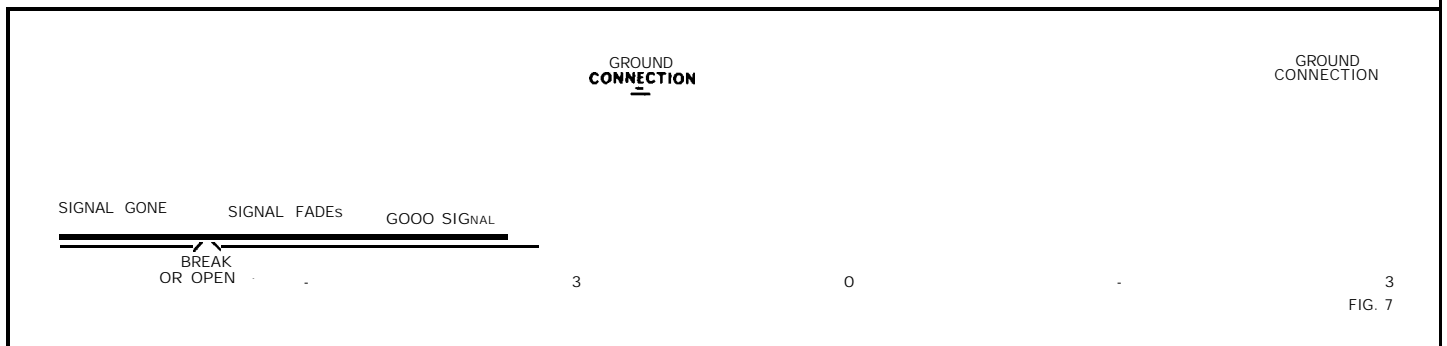

FIG. 7

**Section 7
BATTERIES AND REPLACEMENT**

The transmitter operates on a 12 volt battery. The battery connection is made with a short cable and Cinch-Jones S302CCT or equal connector. The wide blade is positive and the transmitter input is diode protected against accidental reversal.

The battery supplied is a NEDA No. 926, Eveready No. 732, or Burgess No. TW2, 12 volt lantern battery. Two 6 volt batteries, Eveready No. 510S or Burgess F4BP may be used in series and will fit the same space. The Nilsson Model 110 rechargeable 12 volt battery pack will clamp directly into the same space.

The battery drain is from 800 to 1000 M. A., depending upon the transmitter loads. The higher the frequency, the less drain.

The plug in cable allows the use of other batteries such as a car or truck source. A suitable connector cable is easily made for this purpose.

The receiver is powered by two snap top 9 volt transistor radio batteries, connected in series for 18 volts. NEDA No. 1604, Eveready No. 216, or Burgess 2U6 are suitable.

To change receiver batteries, remove the two screws located at each end of the name plate strip and one under the input jack. Slide the chassis out of the phenolic case. Snap one battery on each of the polarized snap connectors, making sure the snaps fit properly.

Receiver battery drain is 10 M.A. standby, 12 M.A. when a strong signal is received.

As with any battery powered device, if the locator is not to be used for long periods of time, batteries should be removed to prevent damage from leaking electrolyte.

Page 10

**Section 8
REPLACEABLE PARTS AND REPAIRS**

Normally no maintenance except battery replacement is required.

Repairs are promptly handled at our factory. Return the instrument, properly packed, to:

**NILSSON ELECTRICAL LABORATORY, INC.
111 EIGHTH AVENUE
NEW YORK, N. Y. 10011
TELEPHONE: (212) 675-7944**

Include in the package suitable paper work and instructions.



**MODEL 110
RECHARGEABLE 12 VOLT BATTERY PACK
will outlast hundreds of 12 volt lantern batteries
SPECIALLY DESIGNED FOR USE WITH
NILSSON MODEL 715 PIPE & CABLE LOCATOR
AND OTHER NILSSON INSTRUMENTS**

The Model 110 battery pack will clamp directly in the same space as the 12 volt lantern battery normally supplied. It can be used over a wide operating temperature range under rugged field conditions.

**RECHARGES OVERNIGHT
CANNOT BE OVERCHARGED**

Plugs into any 110 or 230 volt A.C. outlet. It can be recharged hundreds of times.

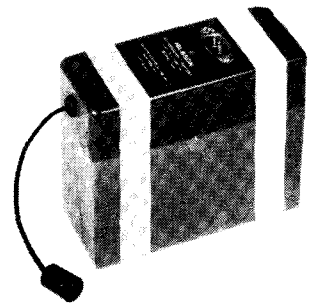

Printed in U.S.A. 3-84